

REVISIONS		
REV	DESCRIPTION	DATE
1	UPDATED AS PER MOONPOOL INSTALLATION AND E-GEN ROOM.	7/8/11
2	UPDATED BERTHING ARRANGEMENT	12/30/13

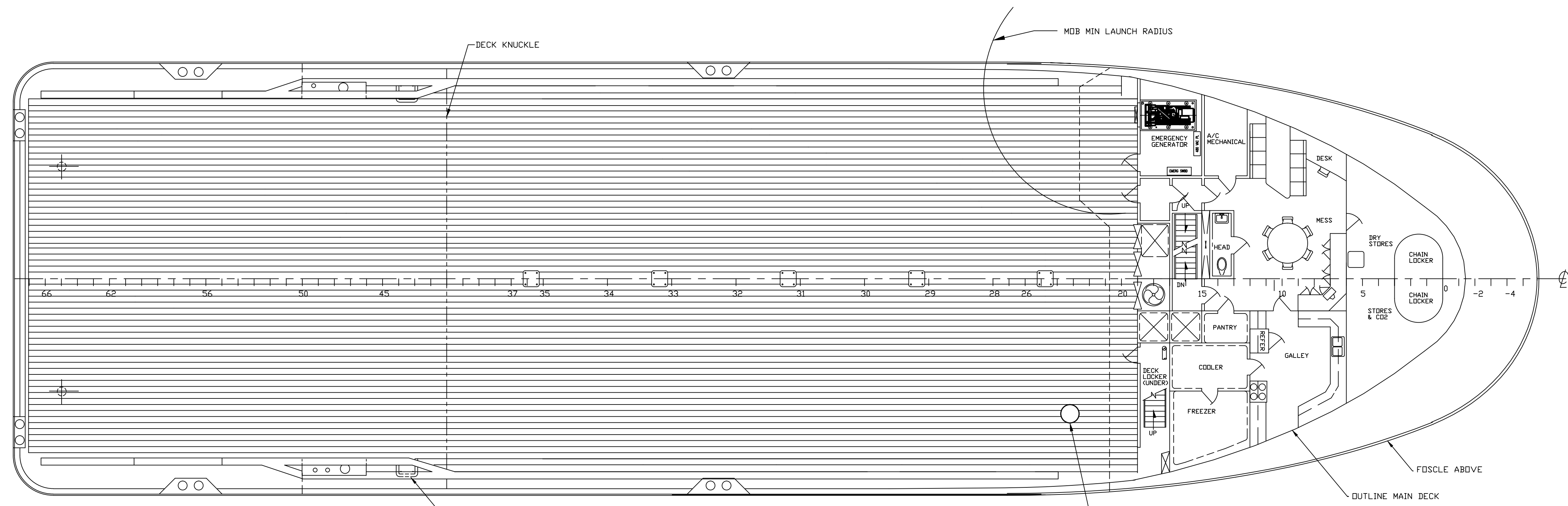

MAIN DECK

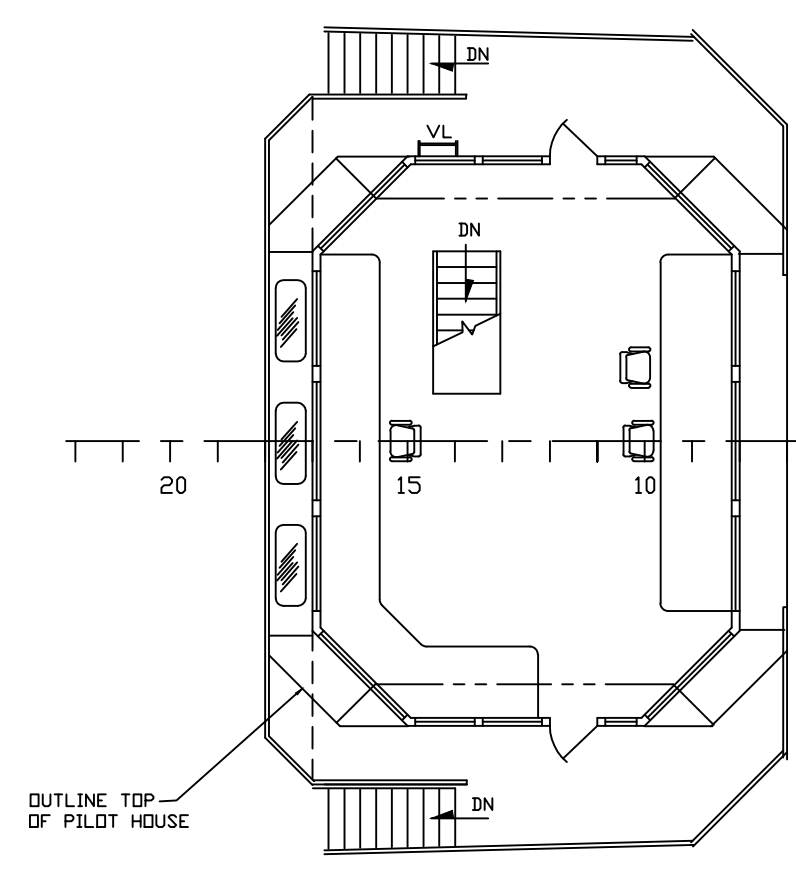

BRIDGE
44'-0" ABOVE BASELINE

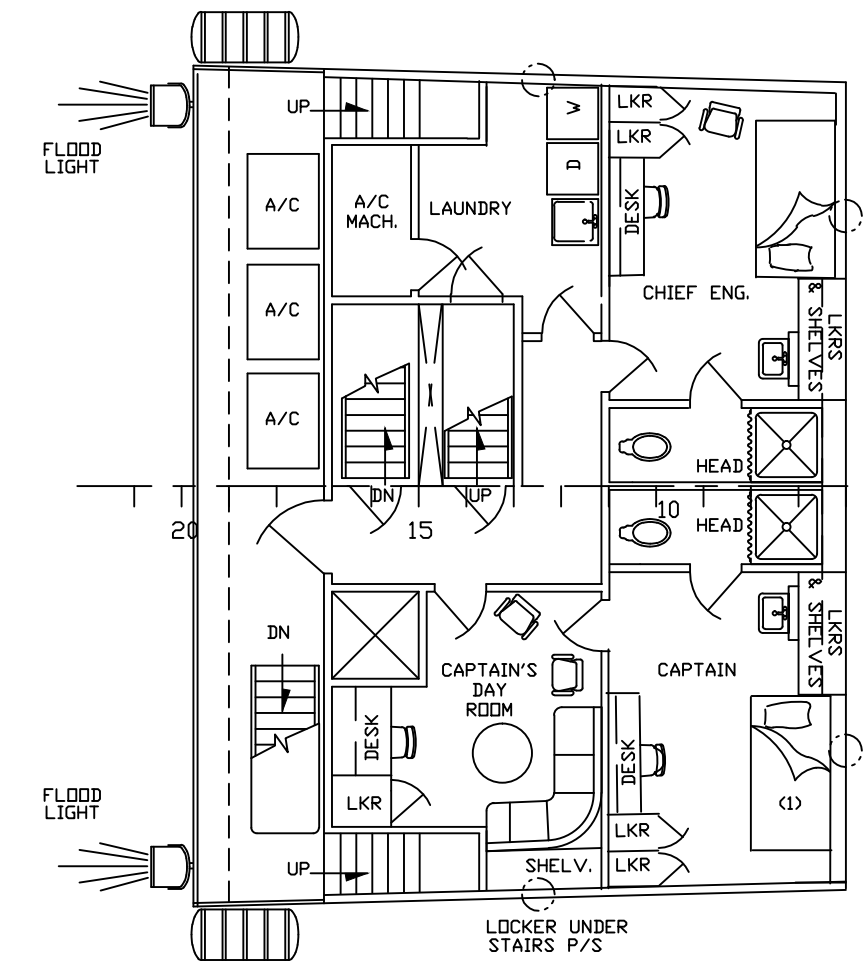

01 LEVEL
35'-0" ABOVE BASELINE

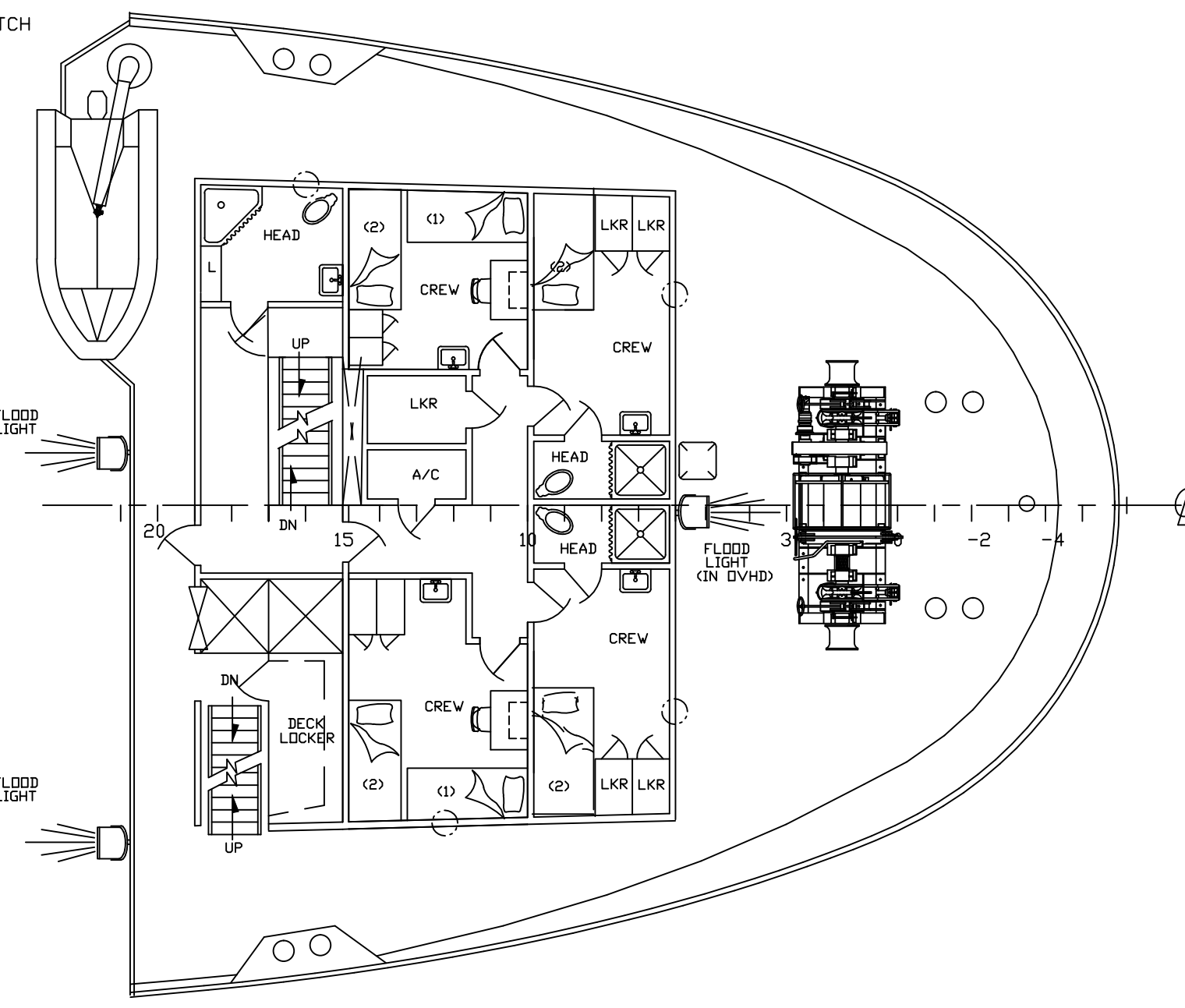

FOCSLE DECK
(26'-0" ABOVE BASELINE)

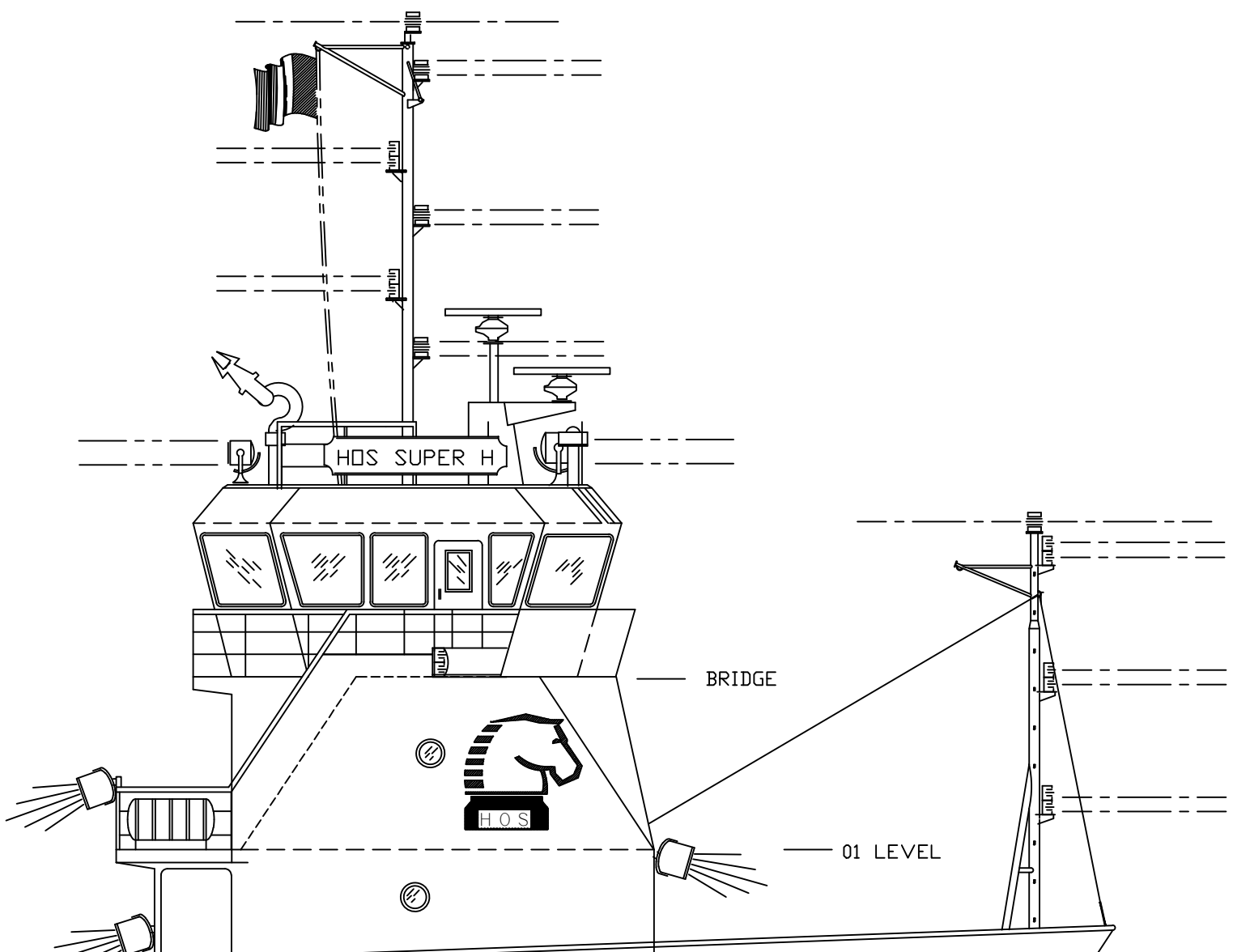

HOS SUPER H

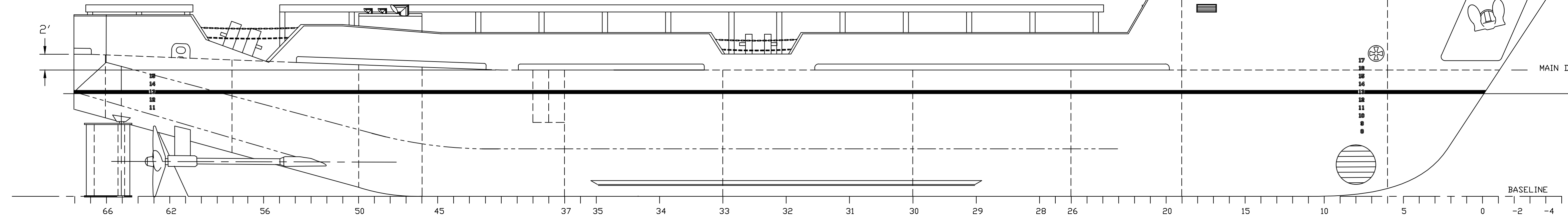

PROFILE

HOS SUPER H

THIS DRAWING, DESIGN CONCEPT AND SPECIFICATIONS ARE THE PROPERTY OF HORNBECK OFFSHORE SERVICES AND ARE FURNISHED ON A CONFIDENTIAL BASIS WITH AN EXPRESSED UNDERSTANDING THAT THEY WILL NOT BE COPIED IN ANY MANNER USED FOR MANUFACTURE, SOLD, TRANSFERRED, NOR USED TO THE DETRIMENT OF SAID FIRM WITHOUT WRITTEN PERMISSION.

HORNBECK OFFSHORE SERVICES

DRAWN BY: C. RANDALL	190'-0" X 54'-0" X 16'-0" OSV
CHK'D BY: F. BERMUDEZ	PROFILE & ARRANGEMENTS
APP'D. BY:	SCALE: 1/8" = 1'-0" DATE: 05/31/2011 REV. 2
PROJECT # 5017	DRAWING # 1.001 SHEET 1 OF 1